



# COMBINED SIGHT GLASS AND LEVEL SWITCH

- Dual high and low level switch operation
- Provides visual indication of fluid levels
- Simple apparatus for leakage detection, fluid level control, etc.
- Easily adaptable to customer requirement
- 4 or 6 switch version available



Alan Cobham Engineering has developed a combined sight glass and dual level switch. Initially developed for a steam oven manufacturer, the unit can be used in a variety of applications such as lubrication oil level indicator, chemical additive feeder level control, etc.

Two reed switches are mounted in the tube and float assembly and can be set to open or close on rising or falling liquid levels. The two end caps, tube, and float wetted parts are manufactured from 316 stainless steel. The borosilicate glass is suitable for a maximum working pressure of 5 bar. The unit can be supplied with flying leads or a terminal box .

Other variants are available which can give up to 6 switching points within the sight glass depending on the sight glass length.

### Technical Specification

Maximum Temperature :	110° C	Glass thickness :	5mm
Maximum Pressure :	5 Bar	Switch rating :	15 Watt
Minimum specific gravity :	0.75	Switch action :	SPST

## Typical Sightglass Configurations

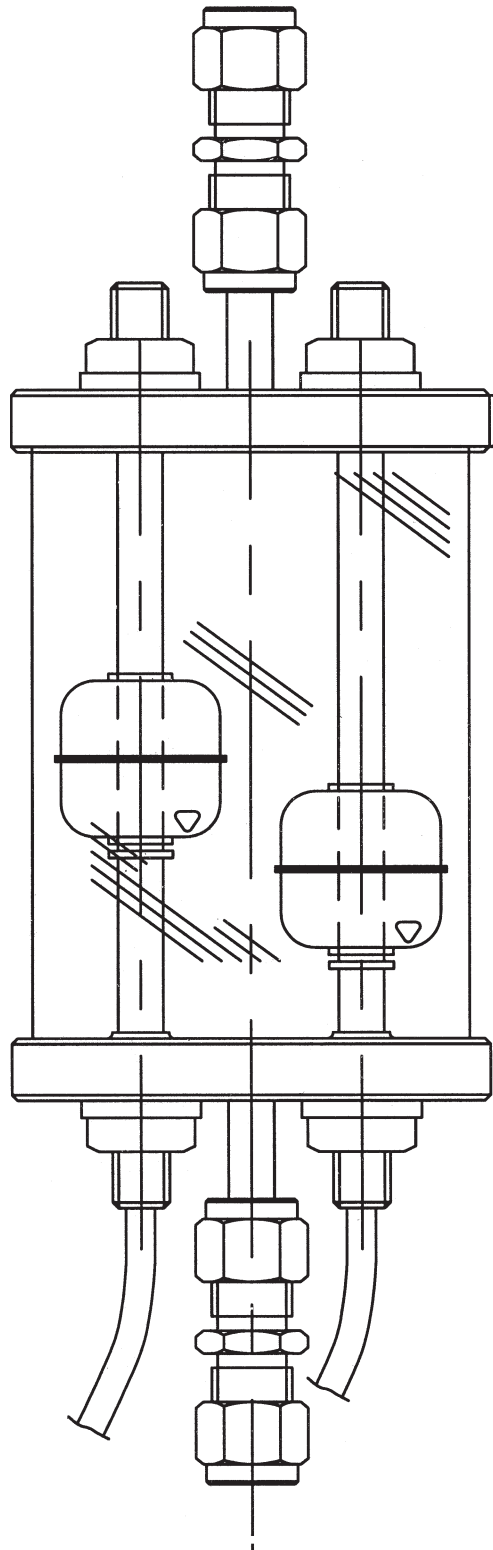
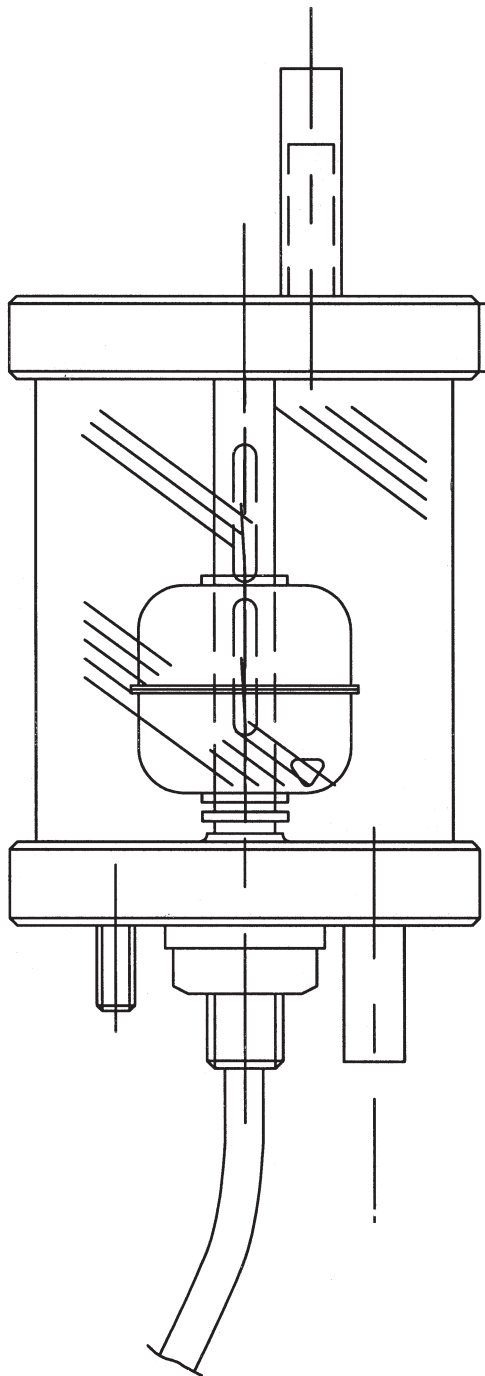

**Cobham Fluid Systems Limited**

Holland Way, Blandford Forum, Dorset, England. DT11 7BJ

Tel: 44 (0)1258 486600 Fax: 44 (0)1258 486601

[www.cobhamfluidsystems.com](http://www.cobhamfluidsystems.com)

[sales@cobhamfluidsystems.com](mailto:sales@cobhamfluidsystems.com)

Copyright: Cobham Fluid Systems.

This publication provides outline information only, which (unless agreed by the Company in writing) may not be used, applied or reproduced for any purpose or form part of any order or contract or be regarded as a representation relating to the products or services concerned. The Company reserves the right to alter without notice the specification, design, price or conditions of supply of any product or service.

**A Flight Refuelling company**



A Collective Member of

**IP** THE INSTITUTE OF PETROLEUM