



2½ and 3 inch STAINLESS STEEL SELF SEALING COUPLINGS



GENERAL INFORMATION

The Avery Hardoll CCMY 8150-series Stainless Steel, Self-sealing Couplings are designed primarily for use in the petroleum, chemical and brewing industries where reliability and safety are of primary concern.

The positive action, bayonet-type locking mechanisms facilitate the coupling and uncoupling of pressurised hoses and pipelines, under no-flow conditions.

A coupling consists of a hose unit and a tank unit, each with its own dust cap. Design features of the couplings include PTFE coating of components to promote ease of operation, selectivity to prevent inadvertent mixing of products and a choice of seal material to suit particular applications.

OPERATION

HOSE UNIT

The hose unit consists of a cam-operated, self-sealing valve assembly, a female bayonet type connector and a threaded hose connector which is free to rotate in its housing. The bayonet connector and valve assembly are interlocked such that the valve can only be opened by fully engaging the hose unit on its matching tank unit.

TANK UNIT

The tank units include a male bayonet-type connector and are flanged or threaded to suit installation requirements. Each unit contains a 'fail-safe' spring-loaded valve seating on a tapered seat. The valve is controlled by the action of coupling and uncoupling the base unit.

- FAIL SAFE TANK UNIT
- HOSE UNIT WITH BUILT-IN SWIVEL
- 60 psi COUPLING PRESSURE
- 150 psi WORKING PRESSURE
- CONSTRUCTED FROM 316 STAINLESS STEEL
- CHOICE OF SEAL MATERIAL

- 1 - HOSE UNIT 2.5 IN BSP**
2 - HOSE UNIT 3 IN BSP

CCMY 8253
CCMY 8254

Material 316 Stainless Steel
 Weight 4.8 kg
 Max. Working Pressure 150 psi
 Max. Coupling Pressure 60 psi

TANK UNIT THREADED VERSION

- 3 - 2.5 IN BSP**
4 - 3 IN BSP

CCMY 8251
CCMY 8252

Material 316 Stainless Steel
 Weight 3 kg
 Max. Working Pressure 300 psi
 Max. Coupling Pressure 60 psi

**5 - TANK UNIT
 2.5 IN FLANGED VERSION**

CCMY 8250

Material 316 Stainless Steel
 Weight 4 kg
 Max. Working Pressure 300 psi
 Max. Coupling Pressure 60 psi

Flanged tank units can be drilled to customers requirements on request

6 - DUST COVER

CCMY 1271

Material Stainless Steel

Seals

Hose and Tank units are available with a choice of seals:

Seal Material	Pt. No. Suffix
Viton	V
Nitrile	N
Chemraz	C
E.P.	E

PRESSURE DROP

PRODUCT: Distillate Specific gravity at 15 deg / 15 deg C = 0.80
 Viscosity at 15 deg C = 2.4 centistokes

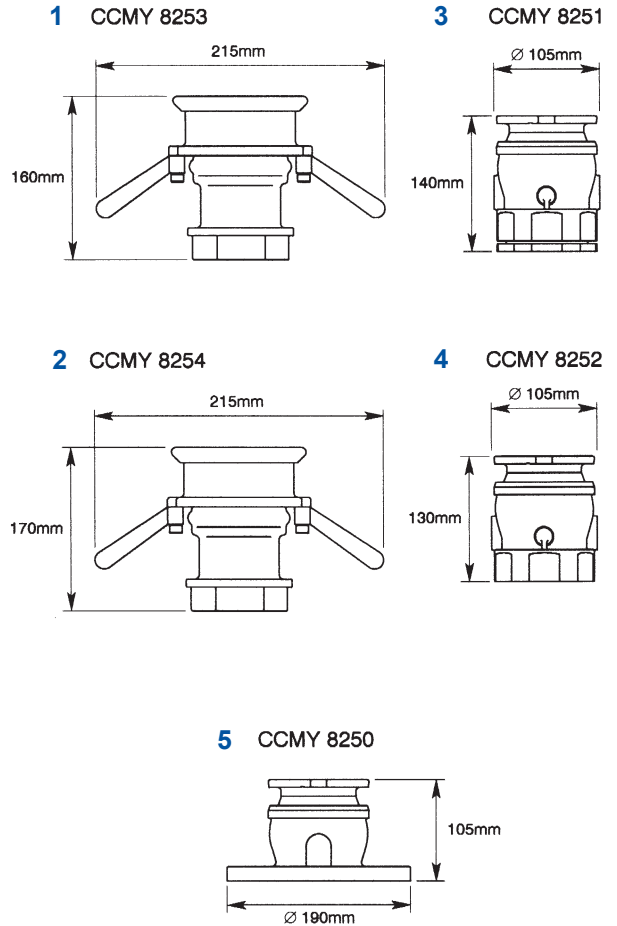
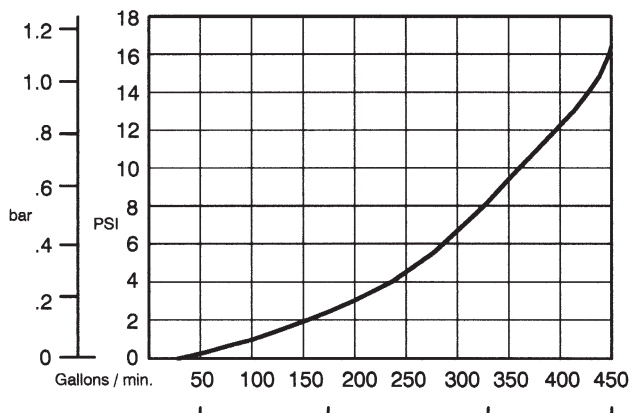

SELECTIVITY

Each unit has seven possible selective positions designated alphabetically from -ST to -SZ

Selective Position Letter	A	B	C	D	E	F	G
Pin & Slot Position	1&2	1&3	1&4	1&5	1&6	1&7	2&3
Selective Position Letter	H	J	K	L	M	N	P
Pin & Slot Position	2&4	2&5	2&6	2&7	3&4	3&5	3&6
Selective Position Letter	Q	R	S	T	U	V	W
Pin & Slot Position	3&7	4&5	4&6	4&7	5&6	5&7	6&7

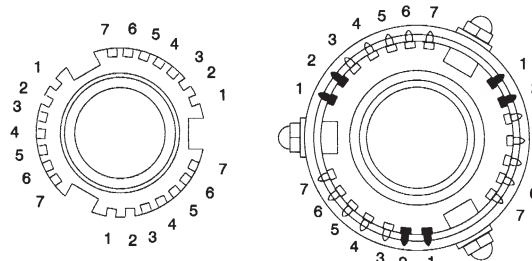

Cobham Fluid Systems Limited

Holland Way, Blandford Forum, Dorset, England. DT11 7BJ
 Tel: 44 (0)1258 486600 Fax: 44 (0)1258 486601
 www.cobhamfluidsystems.com
 sales@cobhamfluidsystems.com

Copyright: Cobham Fluid Systems.

This publication provides outline information only, which (unless agreed by the Company in writing) may not be used, applied or reproduced for any purpose or form part of any order or contract or be regarded as a representation relating to the products or services concerned. The Company reserves the right to alter without notice the specification, design, price or conditions of supply of any product or service.

A Flight Refuelling company



A Collective Member of

