

Couplings

The following couplings are suitable for use with hydrant pit valves.

- CCMY8500M2R2 (4" API adaptor)
- CCMY8501M2R2 (4" API adaptor)
- CCMY5500R2 (4" three point bayonet adaptor)
- CCMY554 or 555 (4" three point bayonet adaptor)
- HUMY403S2DP (2 1/2" three point bayonet adaptor)

For air operated pilot valves and any further information on Avery Hardoll products please contact your local Avery Hardoll distributor.

Ordering Information

PVMY1000M2

- Standard valve with 4" API adaptor and short lanyard

PVMY1004M2

- Standard valve with 4" three point bayonet adaptor

PVMY1008M2

- Standard valve with 2 1/2" three point bayonet adaptor

For 12" and 13" hydrant pit boxes please refer to Data Sheet 125/1 for information on PVMY1100 hydrant pit valves.

Optional Extras

To include the following optional items please add the relevant letter to the part number

- A - Air/lanyard dual pilot valve
- F - 20 mesh strainer
- L - Long (18") lanyard (short lanyard supplied as standard)
- R - Stainless Steel 4" API Adaptor
- S1-6 - Selectivity PVMY1000M2 positions 1-6
- S1-21 - Selectivity PVMY1004M2 positions 1-21
- S1-5 - Selectivity PVMY1008M2 positions 1-5

please advise selectivity position number when ordering.

EXAMPLE: PVMY1000M2AS4 - Standard 4" API valve with Dual pilot valve and selective position 4.



4" three point bayonet adaptor



2 1/2" three point bayonet adaptor



Air/lanyard dual pilot valve



Long (18") lanyard



PVMY1000M2 HYDRANT PIT VALVES



- Compatible with all hydrant couplers conforming to IP and API recommendations
- Meets all the requirements of the IP and API recommendations
- 4 inch API adaptor as standard, 2 1/2 inch and 4 inch bayonet adaptors optional (bayonet versions simply converted to 4 inch API)
- Pressure equalising valve for ease of coupling
- 6 inch base flange drilled in accordance with ANSI 300
- Automatic thermal relief prevents pressure build up
- Lanyard, air operated or dual pilot valve
- Adaptor and pilot valve may be serviced without depressurizing the hydrant
- Stone guard strainer supplied as standard, 20 mesh strainer optional



Cobham Fluid Systems Limited
Holland Way, Blandford Forum, Dorset, England. DT11 7BJ
Tel: 44 (0)1258 486600 Fax: 44 (0)1258 486601
www.cobhamfluidsystems.com
sales@cobhamfluidsystems.com

Copyright: Cobham Fluid Systems.
This publication provides outline information only, which (unless agreed by the Company in writing) may not be used, applied or reproduced for any purpose or form part of any order or contract or be regarded as a representation relating to the products or services concerned. The Company reserves the right to alter without notice the specification, design, price or conditions of supply of any product or service.

A Flight Refuelling company



A Collective Member of
IP THE INSTITUTE OF PETROLEUM

Operation

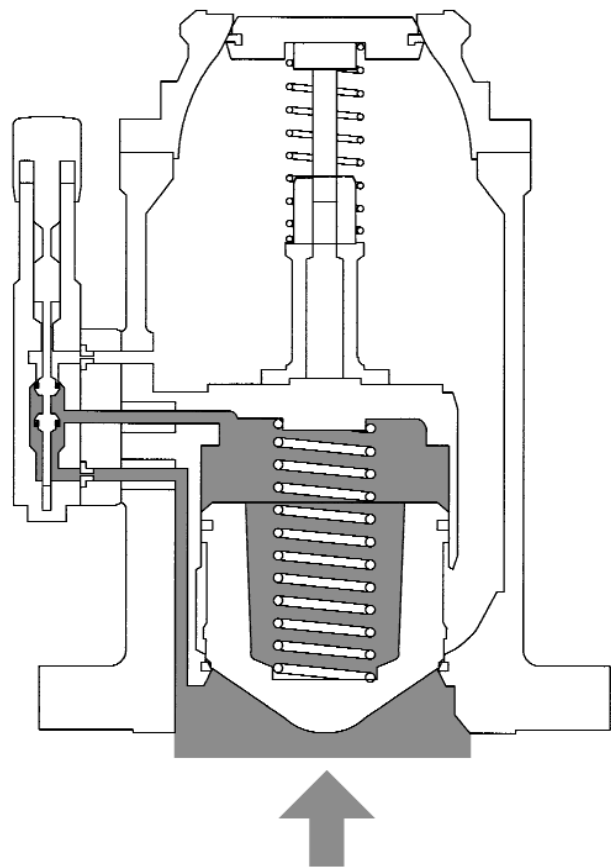

Figure 1 - Pit Valve closed

With the pilot valve closed, fuel pressure from the hydrant line is applied to the bottom face of the piston. At the same time fuel at equal pressure passes through the internal drilling of the guide rod to the top of the piston. Due to an imbalance in surface area and with spring assistance the piston is held closed.

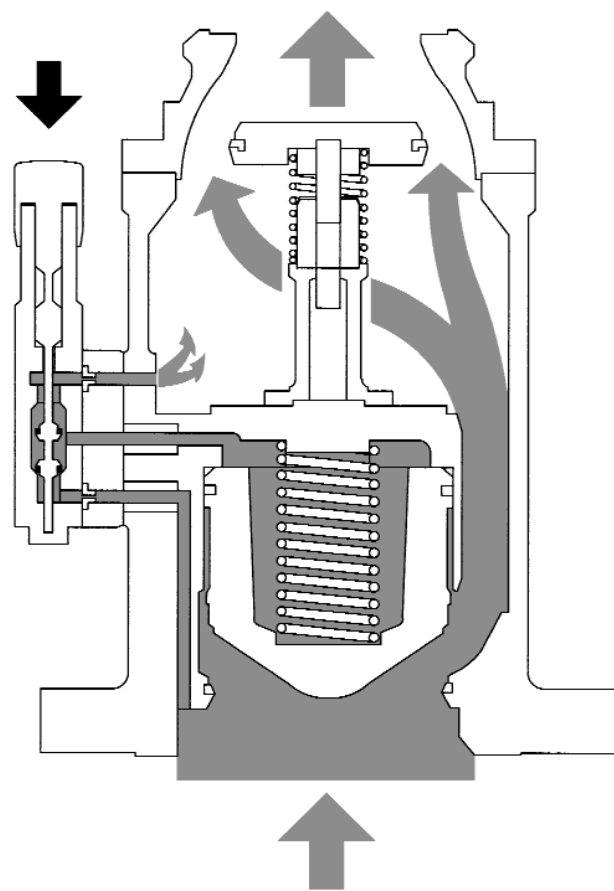

Figure 2 - Pit Valve open

When the pilot valve is opened fuel on top of the piston is released to the downstream side of the valve. Fuel pressure, on the bottom of the piston, now overcomes spring pressure forcing the piston off its seat and allowing fuel to flow with minimum pressure drop.

Specification

MATERIALS

Body
Anodised aluminium alloy, Stainless steel and PTFE with Fluorocarbon and High Nitrile seals.
4" API adaptor - Cast Iron with high performance Fluoropolymer coating (Stainless steel available to special order.)

Specification

Maximum Safe Working Pressure
- 4" adaptors 18.7 bar (275 psi)
- 2 1/2" adaptors 10.3 bar (150 psi)

Hydrostatic Test Pressure
- 4" adaptors 28.0 bar (412 psi)
- 2 1/2" adaptors 15.5 bar (225 psi)

Air Pressure (pneumatically operated pilot valves)
- Minimum 3.4 bar (50 psi)
- Maximum 13.6 bar (200 psi)

Pressure Drop 4"
(IP Specified test rig @ 1000lgpm (1200 US gpm) Without 20 mesh strainer - 1.12 bar (16.3 psi) with 20 mesh strainer - 1.25 bar (18.2 psi)

Pressure Drop 2 1/2"
(IP Specified test rig @ 420 lgpm (500 US gpm) With or without 20 mesh strainer - 1.17 bar (17 psi)

Opening Time
0 - 90% of full flow 5 - 10 seconds

Closing Time
4" adaptors @ 8.1 bar (120 psi) inlet pressure and 1000 lgpm (1200 US gpm) 2 - 5 seconds, over shoot 40 Imp gallons maximum
2 1/2" adaptors @ 8.1 bar (120 psi) inlet pressure and 420 lgpm (500 US gpm) 2 - 5 seconds, over shoot 19.5 Imp gallons maximum

Temperature
Minimum operating temperature -25⁰ C
Maximum operating temperature 135⁰ C

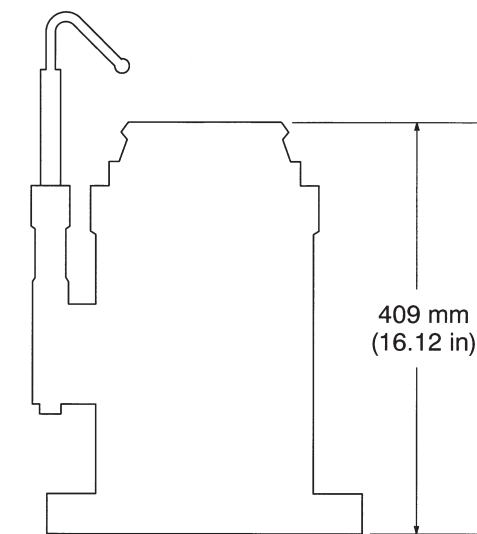

4 inch API Adaptor

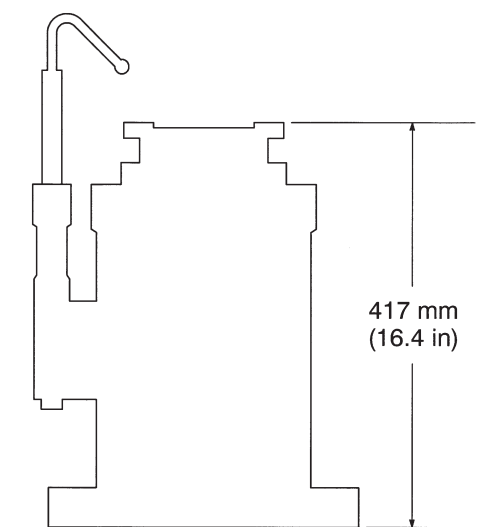

4 inch Three-point Bayonet

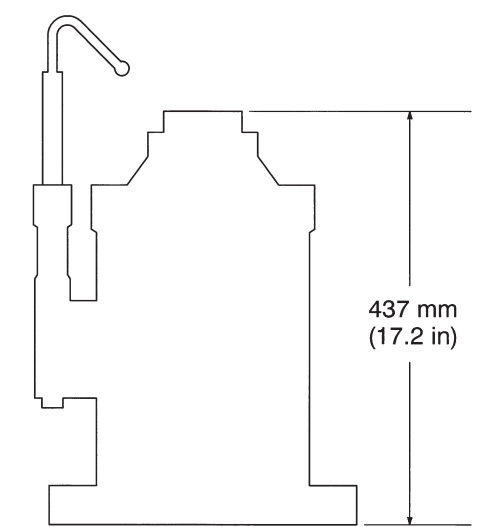

2.5 inch Three-point Bayonet